

# HG150U

## DEMAND EFFICIENCY

The Hyde GUARDIAN **Universal Service™** Ballast Water Treatment system is an effective and reliable solution combining filtration with Ultraviolet (UV) disinfection.

### HG150U Features:

- Smallest footprint on the market
- Optimized size for smaller vessels
- Automatic modes reduce crew time
- UV systems capable of handling fast ballasting turnaround times
- Two-sided chamber reduces maintenance space requirements
- Automatic backflushing filter for heavy organic and sediment loading
- Produces no harmful disinfection by-products

### What's Included:

- Filter
- UV Chamber
- Control Panel
- Power Panel
- Control valves
- Flow meter
- Air supply regulator

### Options available:

- Skid mounting (includes interconnect piping and wiring)
- Hazardous Area certification available
- Easy interface with ships automation
- Isokinetic Sample Port(s)
- Remote Panels



The HG150US assembly mounts major components for ease of installation.

#### Technical Data

Treatment Rated Capacity	150 m <sup>3</sup> /hr
Electrical Supply	380 – 690V · 50/60 Hz · 3 ph
Power Consumption	30 kW Nominal · 45 kW max
Max. Operating Pressure	10 bar
Minimum Flow	18 m <sup>3</sup> /hr
Max. Operating Temperature	55 C

Component	Size (L · W · H) (mm)	Weight (kg)
Skid (Complete Assembly)	1617 · 1028 · 2164	960
Filter	413 · 456 · 1100	192
UV Chamber	1186 · 949 · 587	165
Control Panel	600 · 210 · 760	35
Power Panel	1206 · 406 · 1803	575

FRONT VIEW

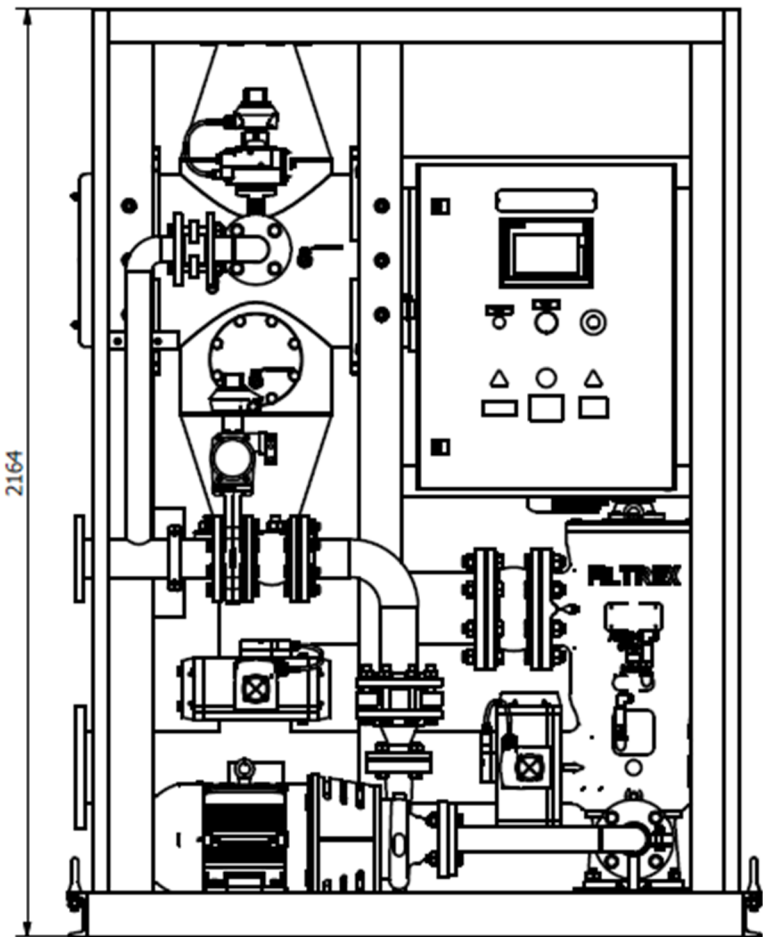

SIDE VIEW

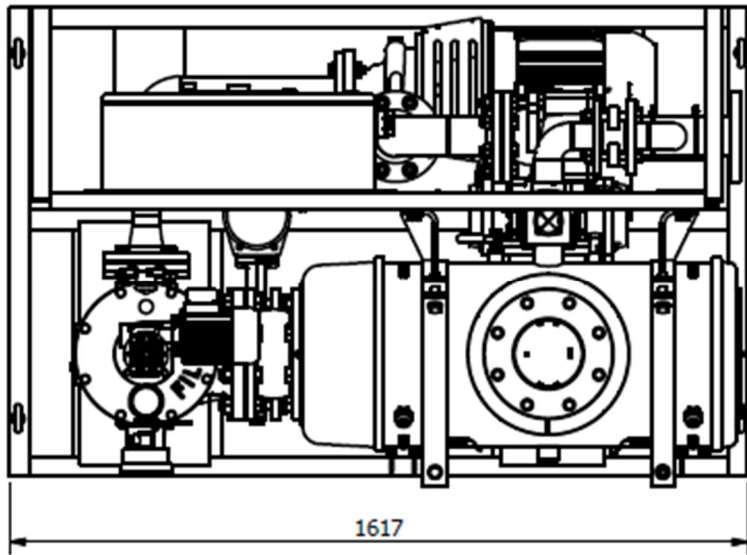
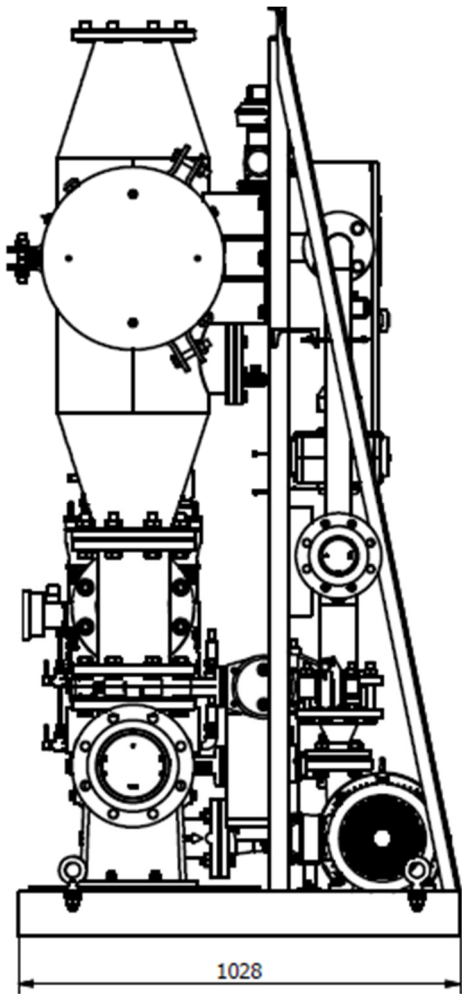

TOP VIEW