

HG300U

DEMAND PERFORMANCE

The Hyde GUARDIAN **Universal Service™** Ballast Water Treatment system is an effective and reliable solution combining filtration with Ultraviolet (UV) disinfection.

HG300U Features:

- Smallest footprint on the market
- Optimized for mid-sized vessels
- Seven automatic modes of operation allowing one-touch operation
- Automatic backflushing filter capable of handling heavy organic and sediment loading
- Tested performance independent of salinity, temperature or UVT
- Two-sided reactor to reduce space

What's Included:

- Filter
- UV Chamber
- Control Panel
- Power Panel
- Control valves
- Flow meter
- Air supply regulator

Options available:

- Skid mounting (includes interconnect piping and wiring)
- Hazardous Area certification available
- Remote panels
- Direct interface to ships automation
- Isokinetic Sample Port(s)
- Gravity operation



The HG300US assembly mounts major components providing the most compact solution available.

Technical Data

Treatment Rated Capacity	300 m ³ /hr
Electrical Supply	380 – 690V · 50/60 Hz · 3 ph
Power Consumption	37 kW Nominal · 58 kW max
Max. Operating Pressure	10 bar
Minimum Flow	24 m ³ /hr
Max. Operating Temperature	55° C

Component	Size (L · W · H) (mm)	Weight (kg)
Skid (Complete Assembly)	1617 · 1063 · 2241	1275
Filter	475 · 517 · 1300	322
UV Chamber	1075 · 949 · 587	165
Control Panel	600 · 210 · 760	35
Power Panel	1800 · 406 · 1803	865

FRONT VIEW

SIDE VIEW

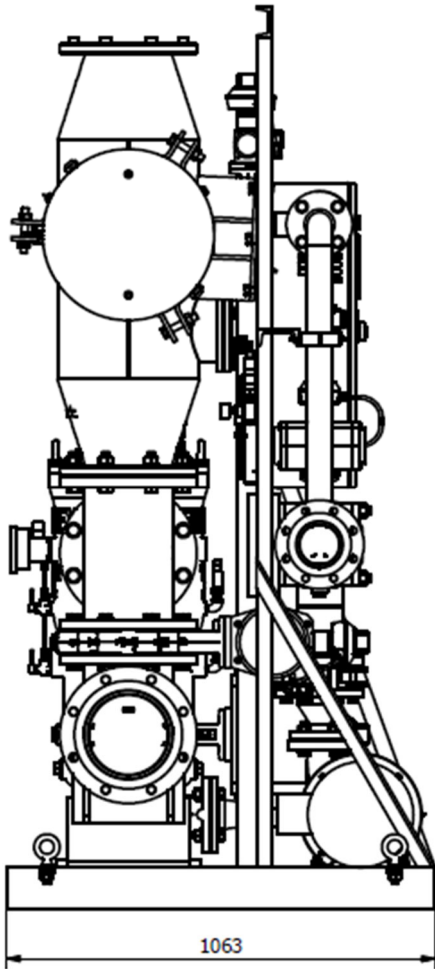
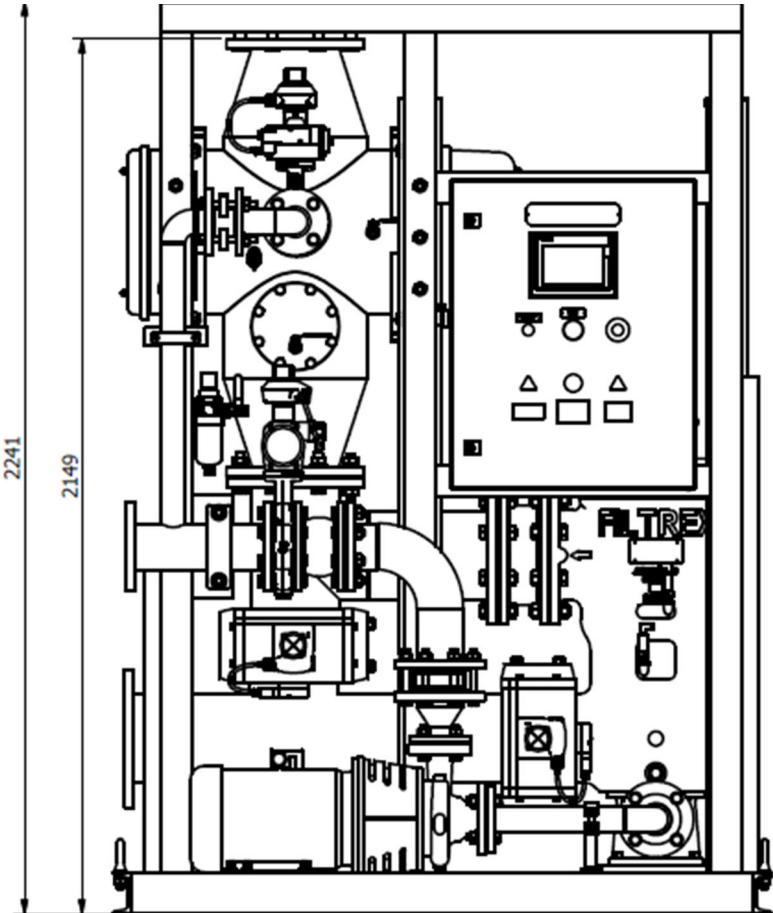

TOP VIEW

