

HG60U

DEMAND RUGGED

The Hyde GUARDIAN **Universal Service™** Ballast Water Treatment system is an effective and reliable solution combining filtration with Ultraviolet (UV) disinfection.

HG60U Features:

- Smallest footprint on the market
- Removable reactor cartridge to improve maintainability
- Seven automatic modes of operation for one-touch operation
- Rugged cast body design to meet extended life expectancy
- Automatic backflushing filter capable of handling heavy organic and sediment loading
- Produces no harmful disinfection by-products

What's Included:

- Filter
- UV Chamber
- Control Panel
- Power Panel
- Control valves
- Flow meter
- Air supply regulator

Options available:

- Skid mounting (includes interconnect piping and wiring)
- Easy interface with ships automation
- Isokinetic Sample Port(s)
- Remote Panels

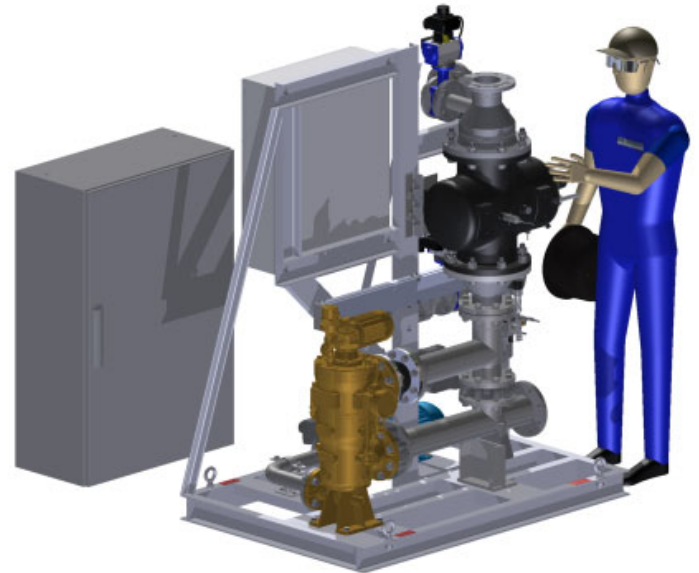

The HG60US assembly mounts major components to streamline installation.

Technical Data

Treatment Rated Capacity	60 m ³ /hr
Electrical Supply	380 – 690V · 50/60 Hz · 3 ph
Power Consumption	12 kW Nominal · 18 kW max
Max. Operating Pressure	10 bar
Minimum Flow	6 m ³ /hr
Max. Operating Temperature	55 C

Component	Size (L · W · H) (mm)	Weight (kg)
Skid (Complete Assembly)	1451 · 1000 · 1981	735
Filter	375 · 374 · 811	98
UV Chamber	922 · 696 · 338	85
Control Panel	600 · 210 · 760	35
Power Panel	1200 · 400 · 1800	373

FRONT VIEW

SIDE VIEW

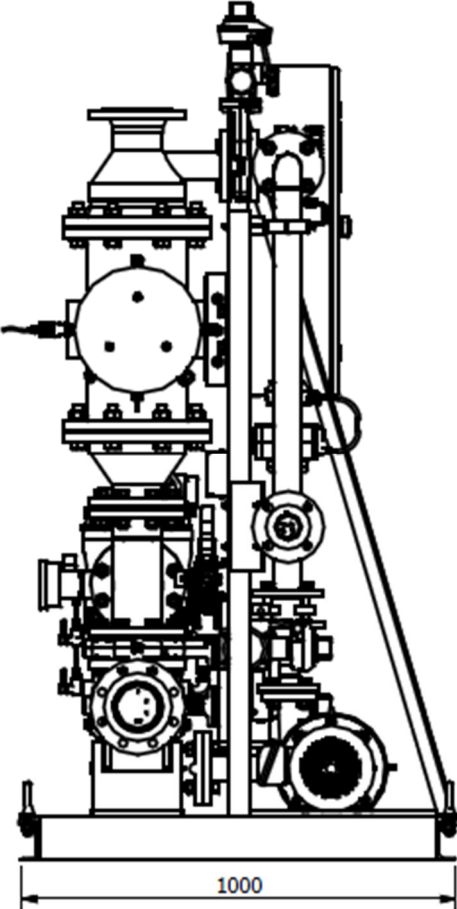
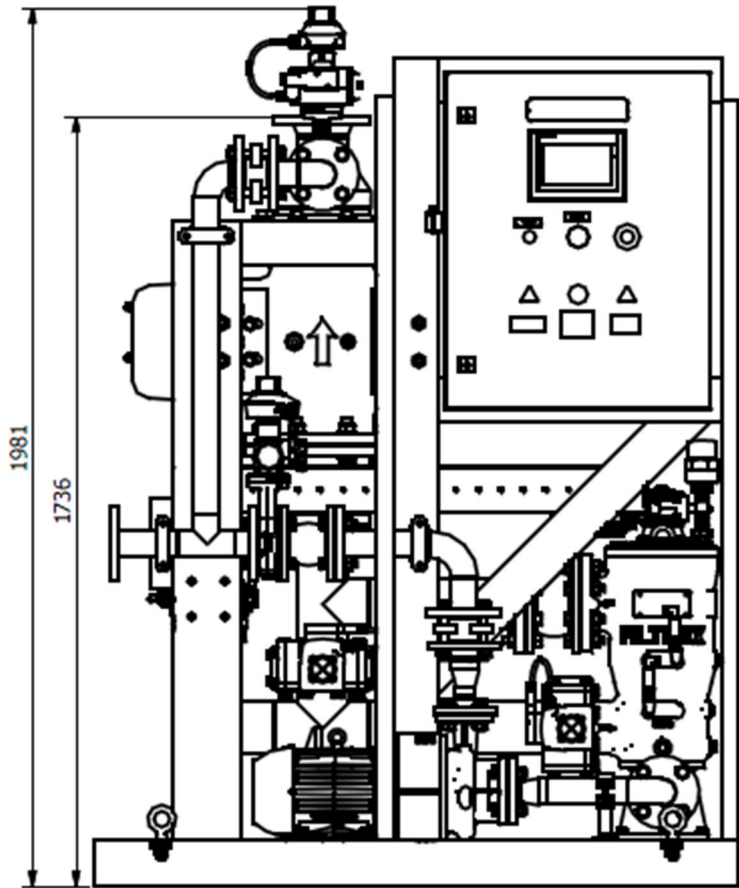

TOP VIEW

